

National Centre for Physics, Qaid-I-Azam University  
October 20<sup>th</sup>, 2003

An aerial photograph of a rural landscape with fields and roads. A red oval outline is drawn over the landscape, and a pink rectangular box is centered within it. The text 'LHC: Physics, Status & Prospects' is written in yellow inside the pink box.

LHC: Physics, Status &  
Prospects

John Ellis,  
CERN, Geneva, Switzerland

# The Large Hadron Collider (LHC)

Proton-Proton Collider

7 TeV + 7 TeV



Luminosity =  $10^{34} \text{cm}^{-2} \text{sec}^{-1}$

Primary targets:

- Origin of mass
- Nature of Dark Matter
- Primordial Plasma
- Matter vs Antimatter

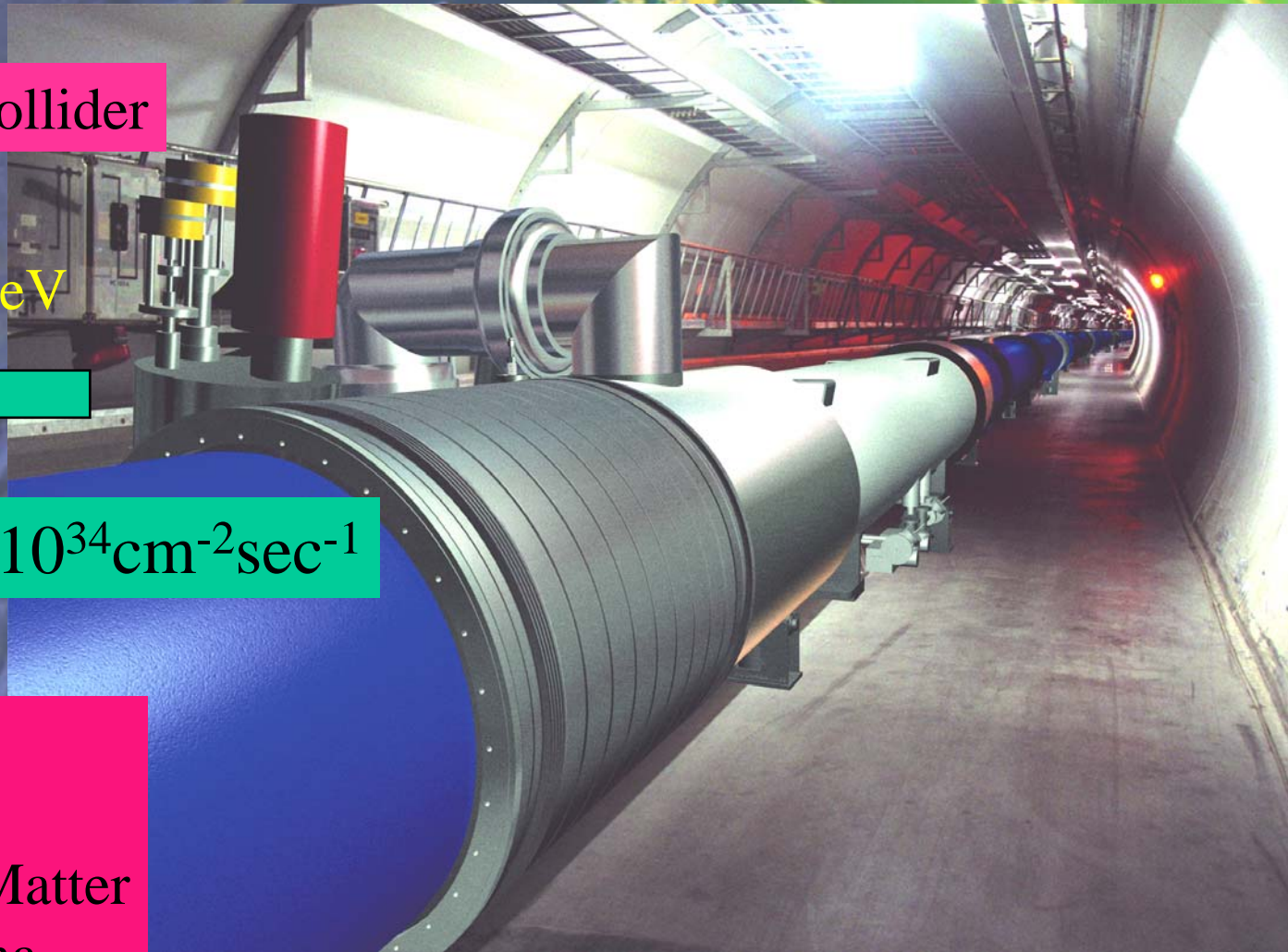

# The First Direct Exploration of the TeV Scale ...

- Why is this interesting?

Any new energy range takes us deeper inside matter, but also ...

- Several reasons to expect new physics:

Origin of particle masses

Stabilization of gauge hierarchy

Unification of couplings

Dark matter

$g - 2$  of muon

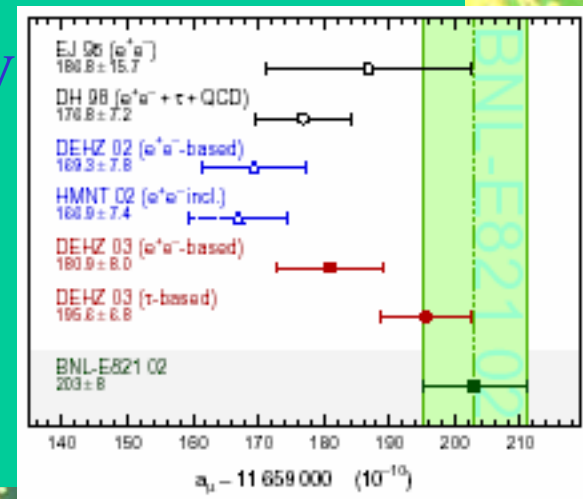

# Production of Inner Cable for Magnets

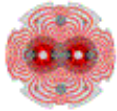

LHC Progress  
Dashboard

Accelerator  
Technology  
Division

Superconducting cable 1

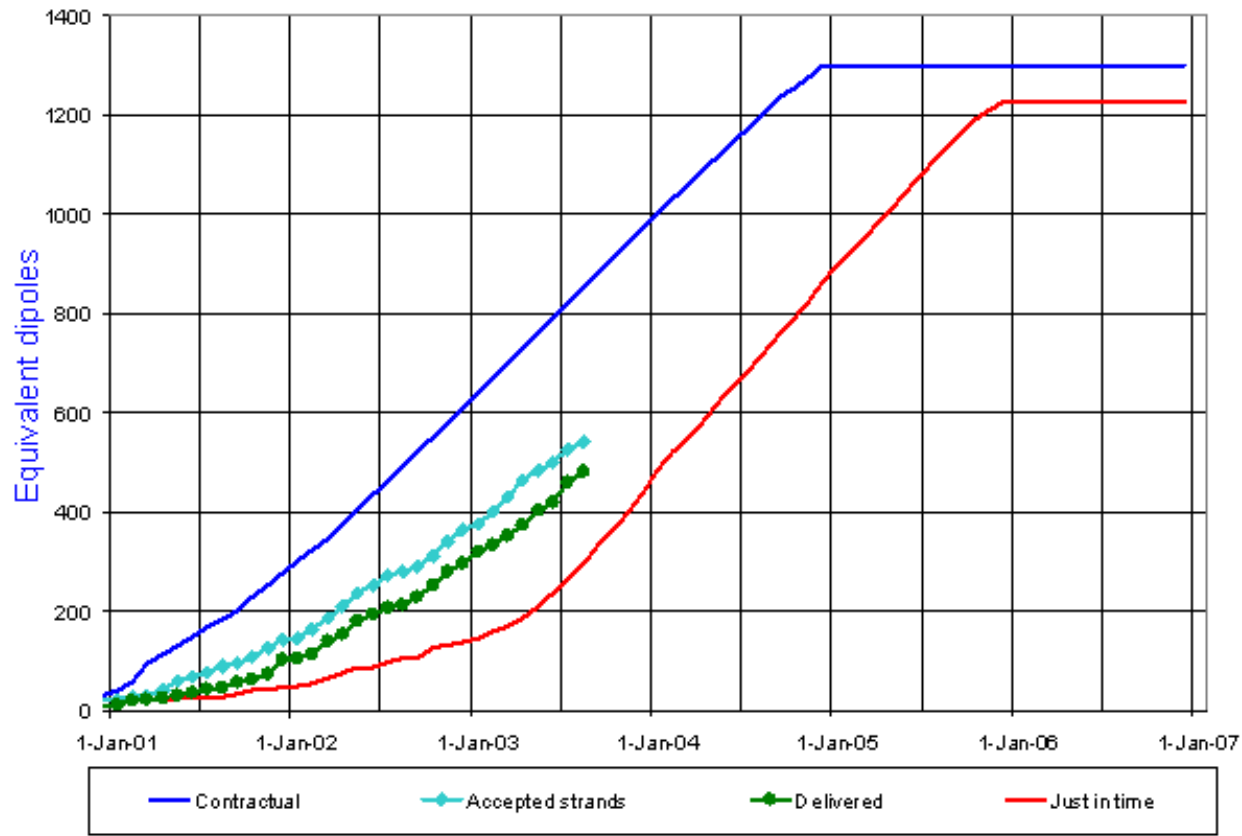

Updated 31 Aug 2003

Data provided by A

See more on the CERN website

# Magnet Cold Masses Stored at CERN



# Cryoline Installation



Started at Point 8  
July 21, 2003



# LHC hardware from CERN Non-Member States



Russia:  
Also USA,  
Japan,  
Canada,  
India

Warm dipoles from  
the Budker Institute  
(Novosibirsk)  
stored at CERN

# Overall View of the Large Hadron Collider (LHC)

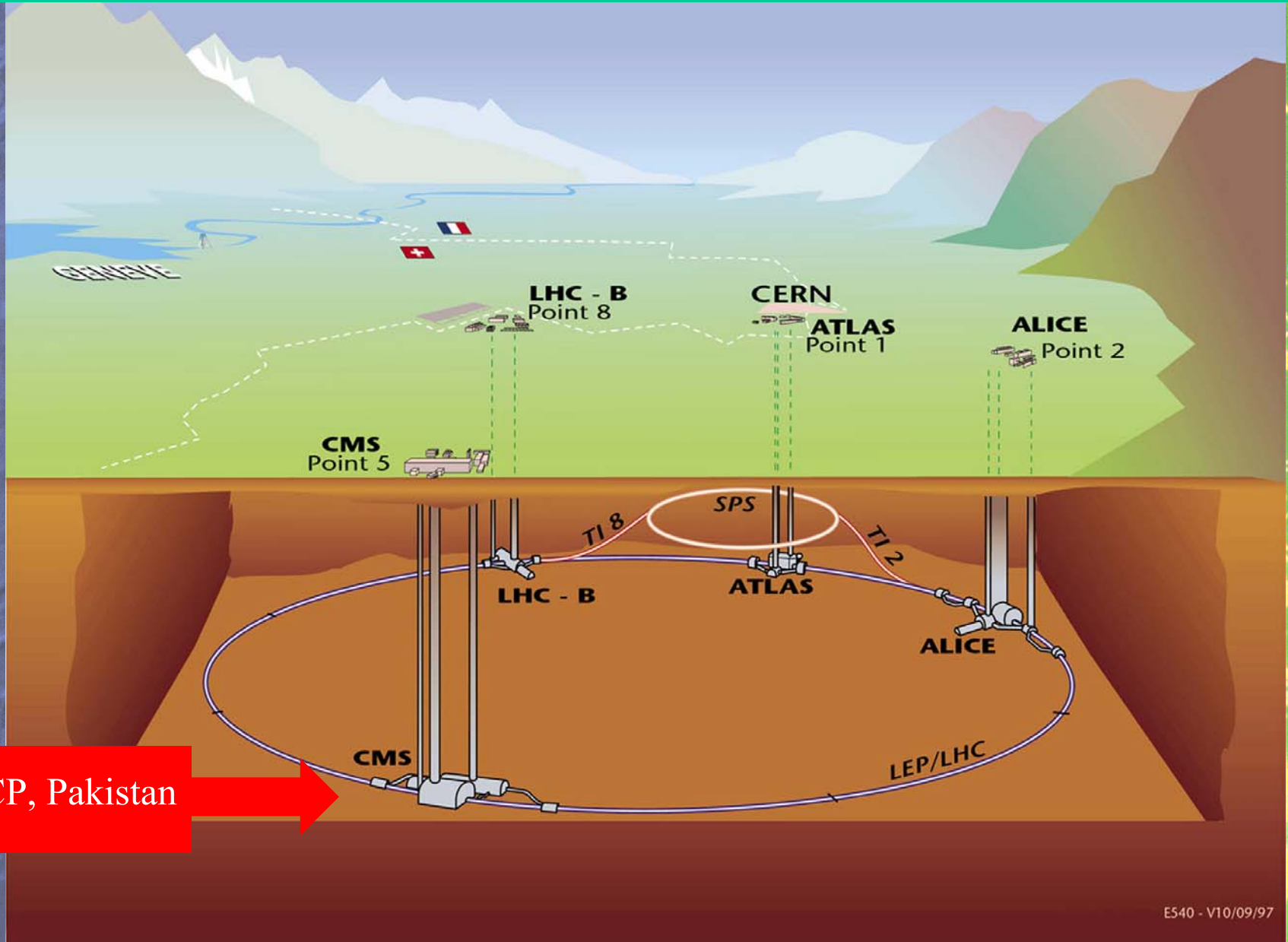

NCP, Pakistan →

# Site of CMS Construction

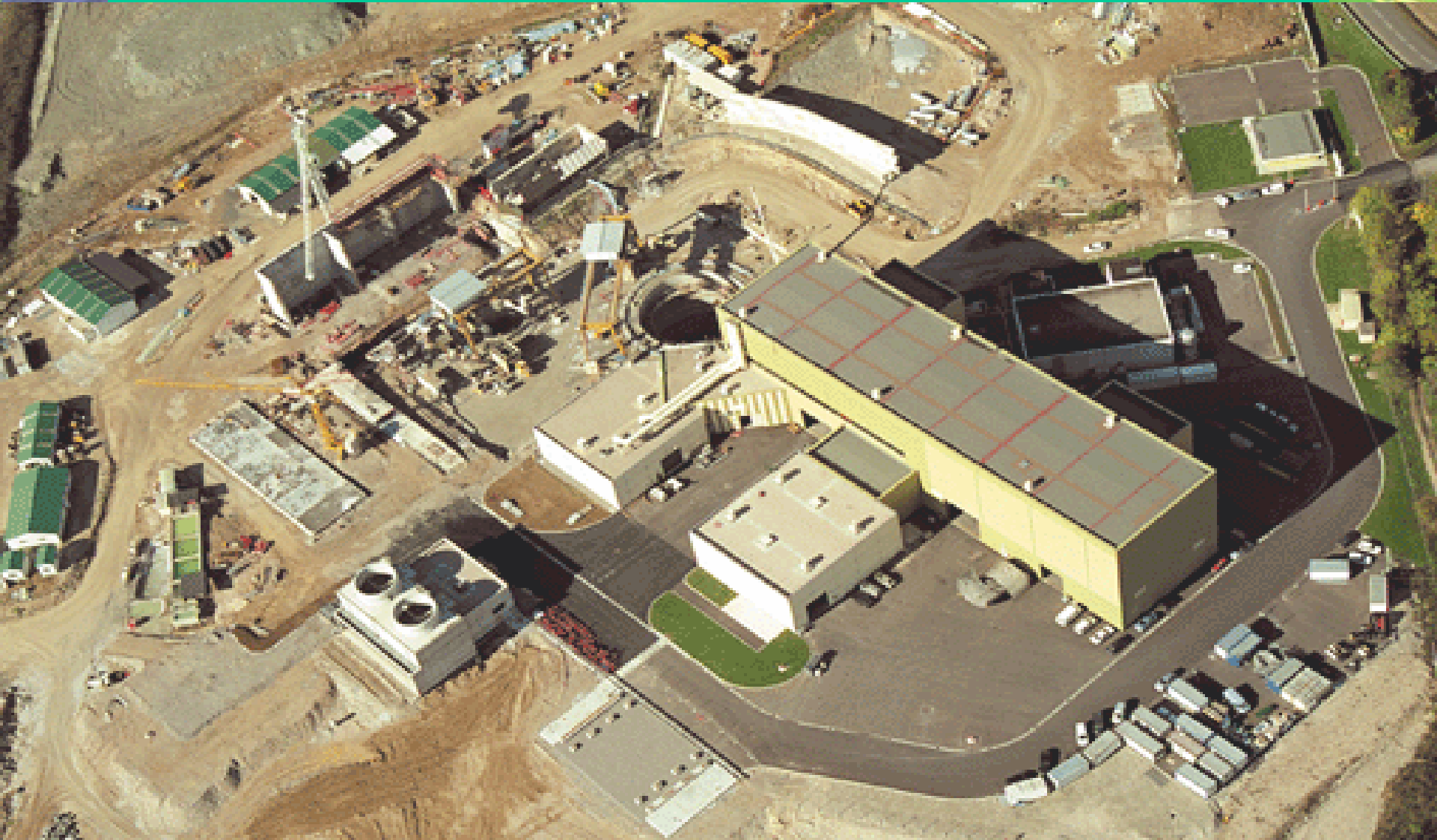

# CMS, Point 5

Shafts leading down to  
CMS pit

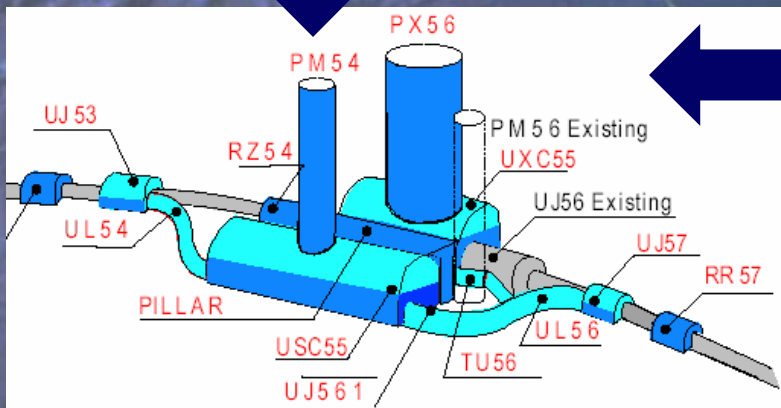
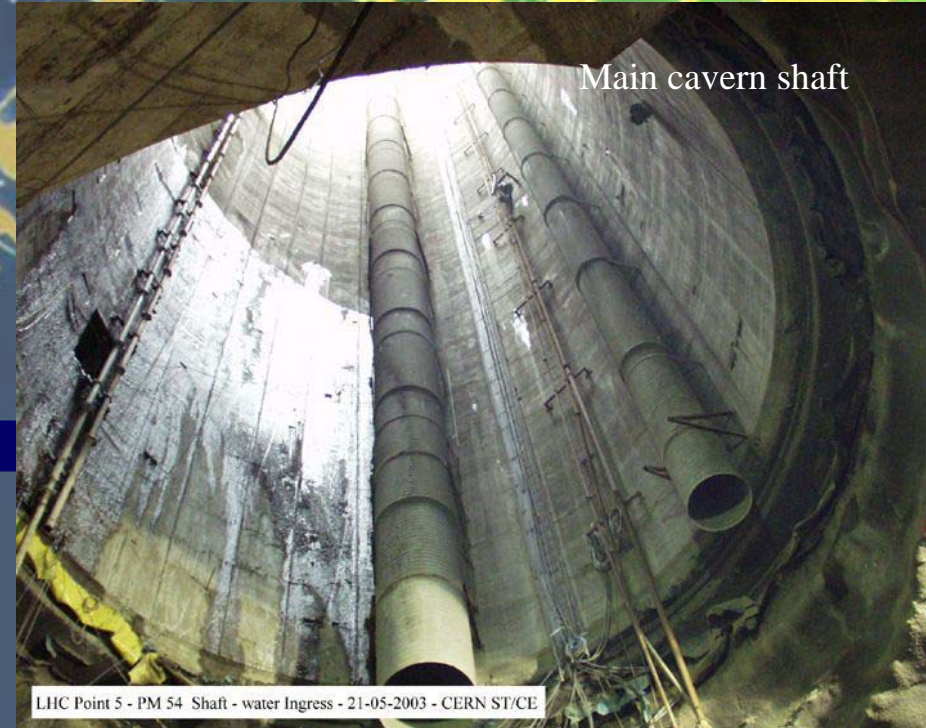

# CMS Experiment

**SUPERCONDUCTING  
COIL**

**CALORIMETERS**

**ECAL**  
Scintillating  
PbWO<sub>4</sub> crystals

**HCAL**  
Plastic scintillator/  
brass sandwich

**IRON YOKE**

**TRACKER**

Silicon  
Micro-strip  
Pixels

Total weight : 12,500 t  
Overall diameter : 15 m  
Overall length : 21.6 m  
Magnetic field : 4 Tesla

**MUON BARREL**

**MUON  
ENDCAPS**

**Drift Tube  
Chambers**

**Resistive Plate  
Chambers**

**Cathode Strip Chambers  
Resistive Plate Chambers**

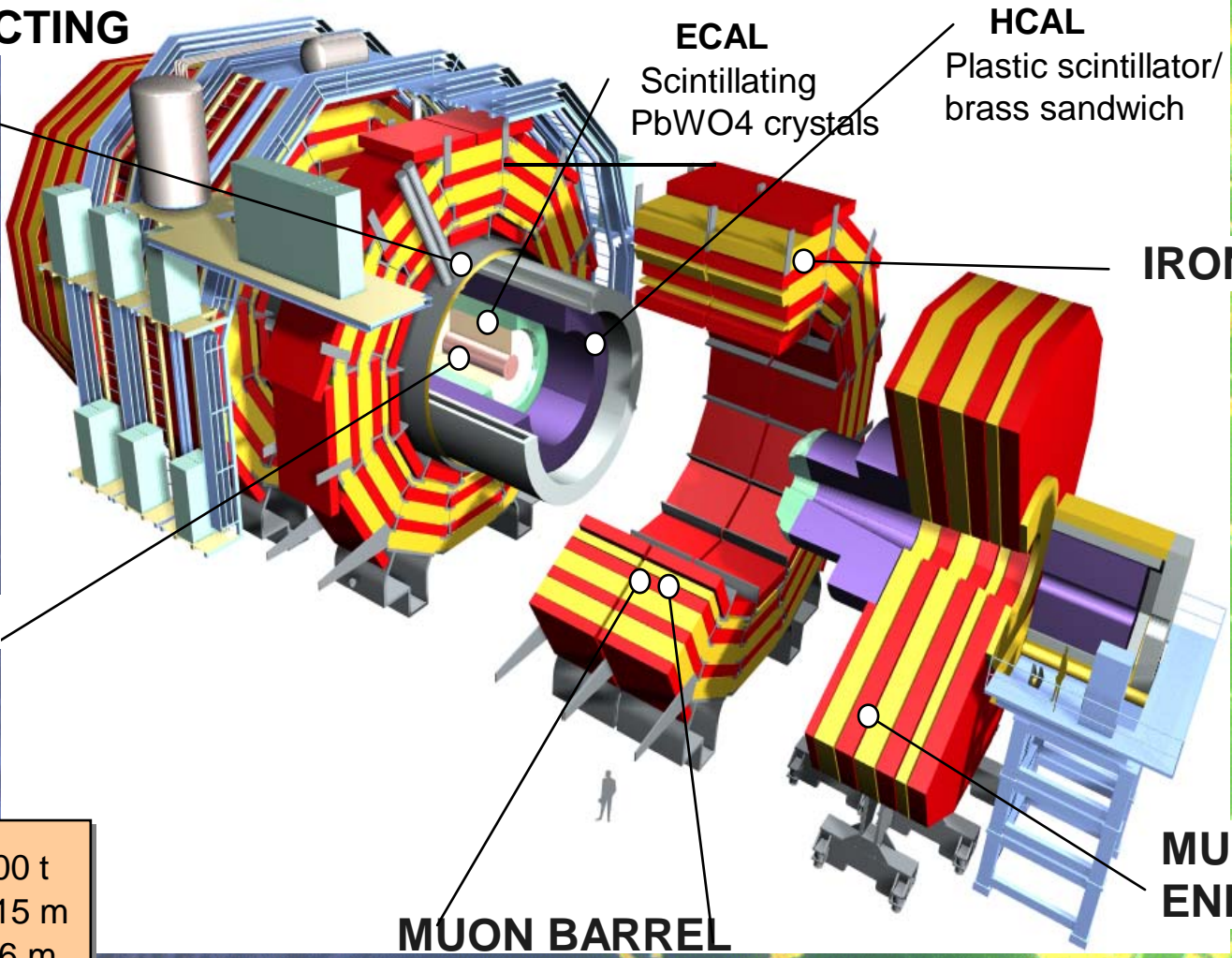

# CMS: Superconducting Coil Insertion Test



# CMS: Hadronic Calorimeters

One end-cap complete,  
other in Dec. 03



Barrel complete, install  
electronics by June 04



# ALICE: Detector for Heavy-Ion Collisions



# The Physics Scope of the LHC

## Interesting cross sections

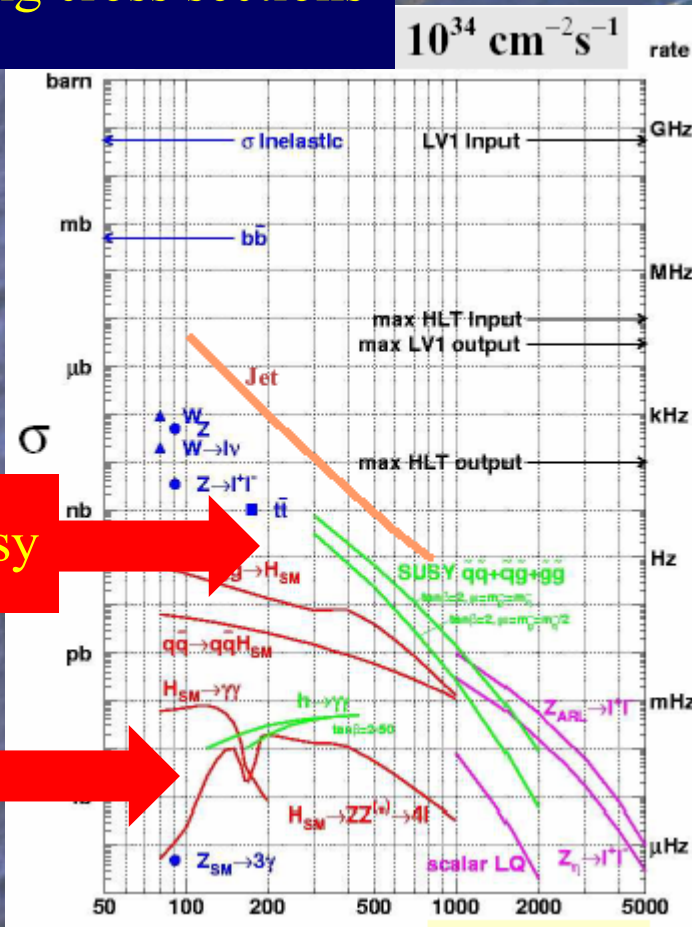

Susy

Higgs

## Bread-and-butter physics

W

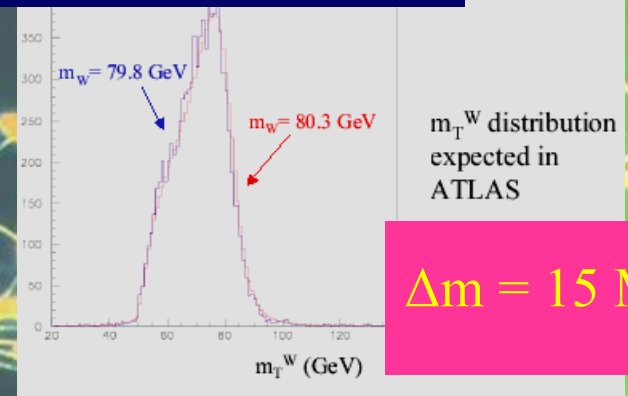

$\Delta m = 15 \text{ MeV}$

top

Selection :

- two b-tagged jets
- one lepton
- $E_T^{\text{miss}} > 20 \text{ GeV}$
- two more jets with  $|m_{jj} - m_W| < 20 \text{ GeV}$

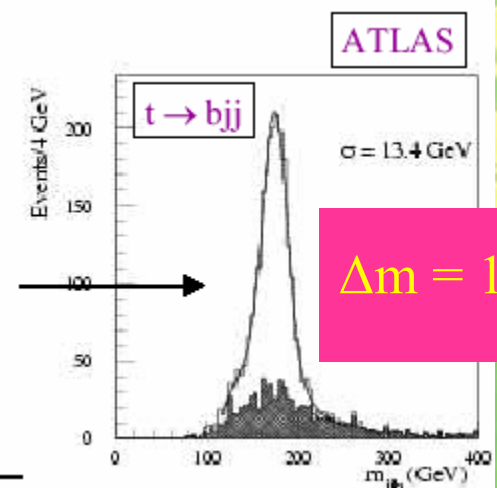

$\Delta m = 1 \text{ GeV}$

# The Role of the Higgs Boson

- Massless gauge bosons, e.g. the photon  
has 2 polarization states: +1, -1
- Massive gauge bosons, e.g., W, Z
- Need additional polarization state  
with zero spin projection
- Provided by scalar field  
as postulated by Higgs, Brout and Englert
- Minimal Standard Model has extra particle  
as pointed out by Higgs: the Higgs boson

# Searches for the Higgs Boson

## Indirect:

- Precision electroweak measurements at LEP, SLC, etc
- Predicted successfully  $m_t = 160 - 180 \text{ GeV}$
- Sensitive to mass of Higgs boson  
 $m_H < 200 \text{ GeV} ?$

## • Direct:

- LEP Searches for  $e^+ e^- \rightarrow Z + H$
- Hint seen in late 2000 now  $< 2 \sigma$

Current Limit:

$$m_H > 114.4 \text{ GeV}$$

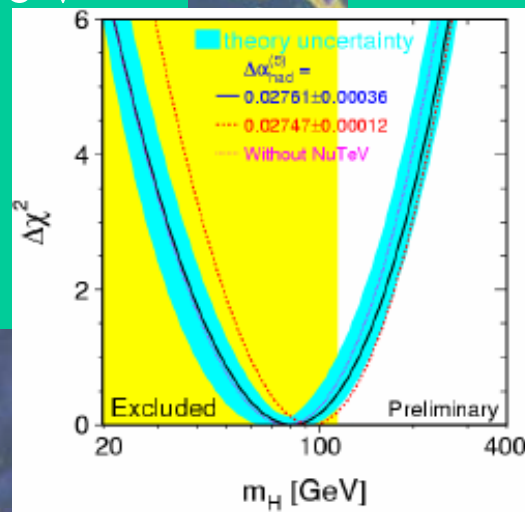

# A Higgs Event in CMS

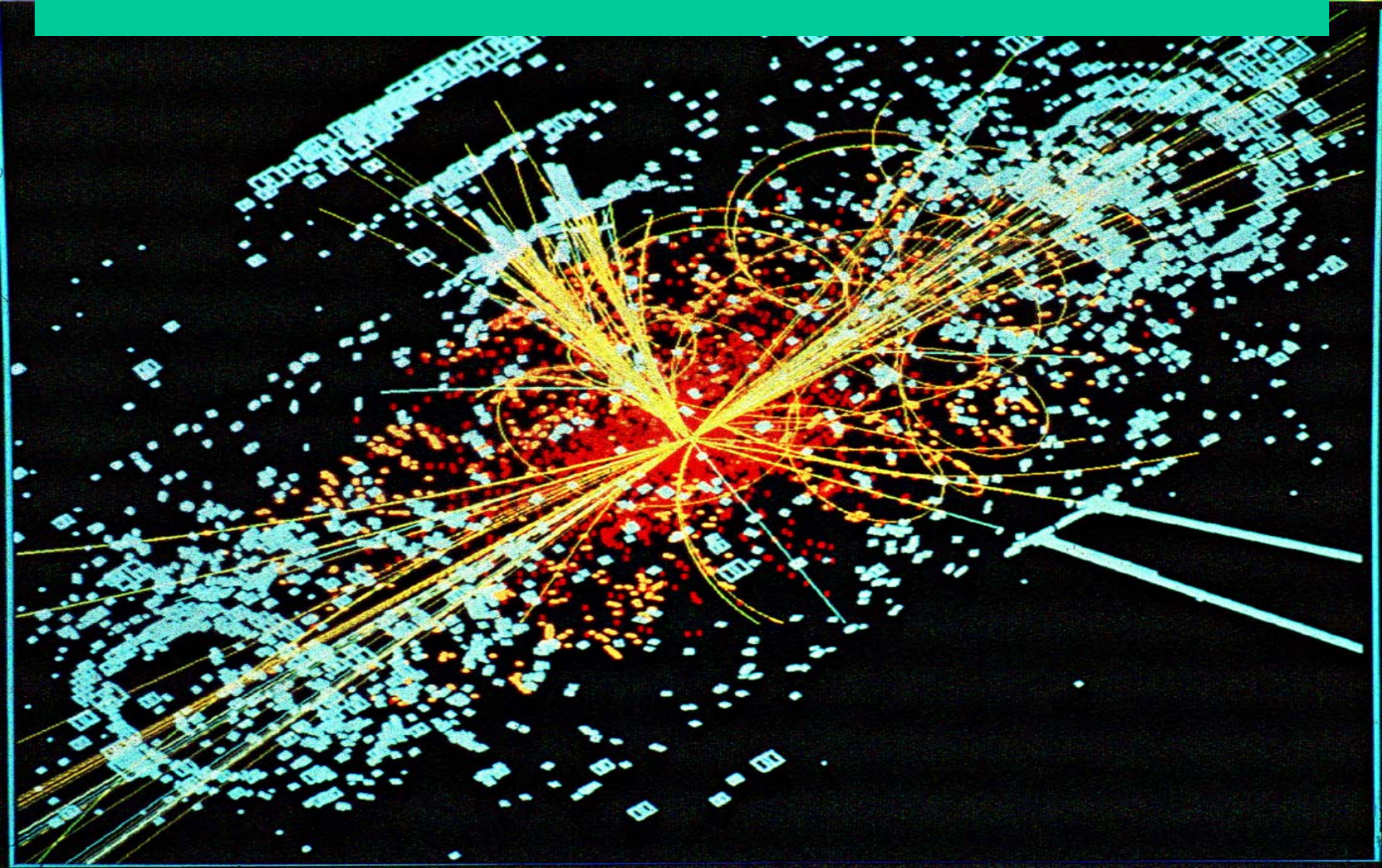

# Some Sample Higgs Signals

$\gamma\gamma$

$ZZ^* \rightarrow 4l$

$\Delta m/m \sim 0.1\%$

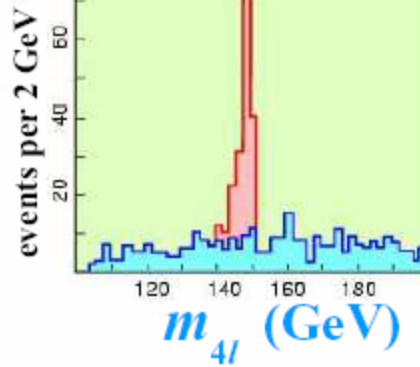
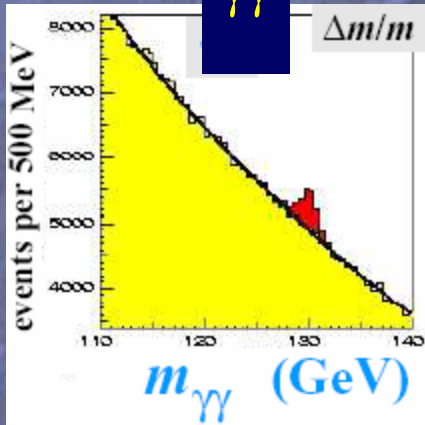

$ttH$

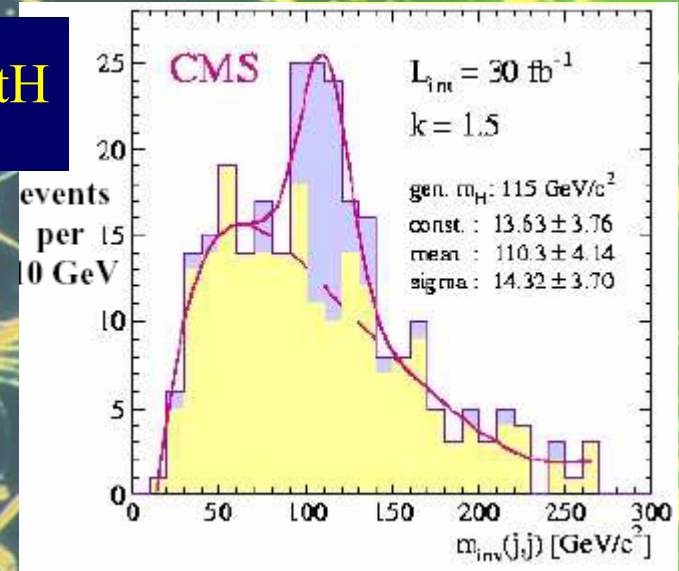

$bbH$

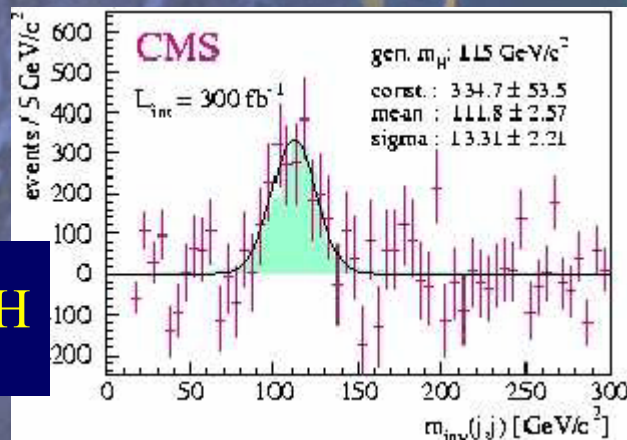

# Higgs Detection at the LHC

The Higgs may be found quite quickly ...

... in several different channels

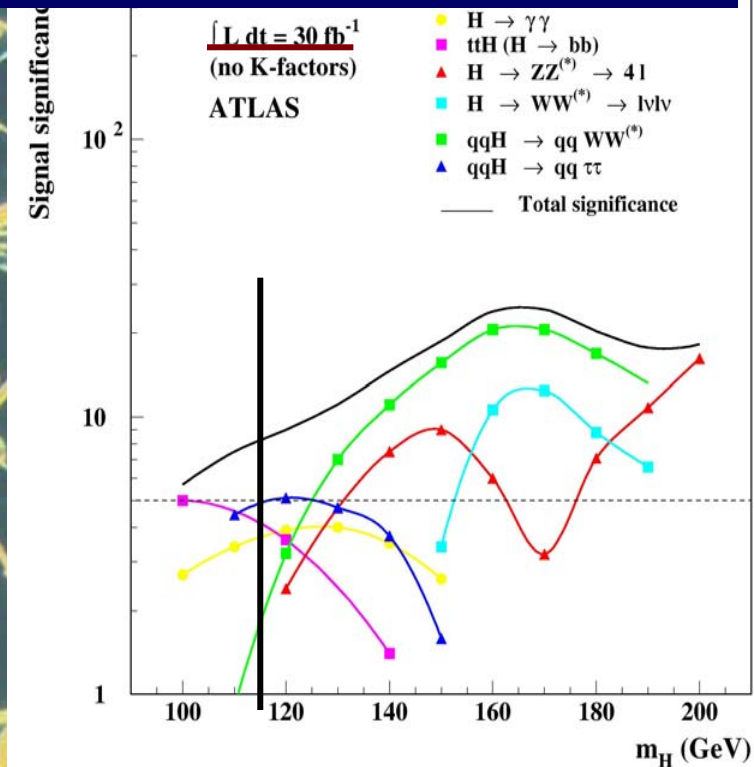
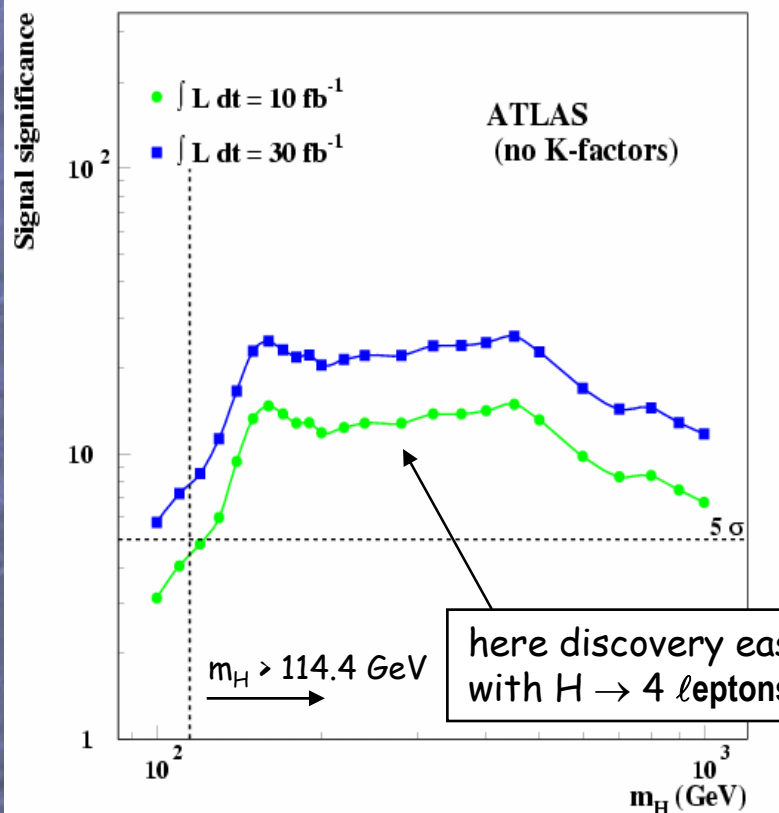

# Why Supersymmetry?

- Hierarchy problem: why is  $m_W \ll m_P$  ?

( $m_P = 10^{19}$  GeV is scale of gravity)

- Alternatively, why is

$$G_F = 1/m_W^2 \gg G_N = 1/m_P^2 ?$$

- Or, why is

$$V_{\text{Coulomb}} \gg V_{\text{Newton}} ? \quad e^2 \gg G m^2 = m^2 / m_P^2$$

- Set by hand? What about loop corrections?

$$\delta m_{H,W}^2 = O(\alpha/\pi) \Lambda^2$$

- Cancel boson loops  $\Leftrightarrow$  fermions

- Need  $|m_B^2 - m_F^2| < 1 \text{ TeV}^2$

# Other Reasons to like Susy

It enables the gauge couplings to unify

It stabilizes the Higgs potential for low masses

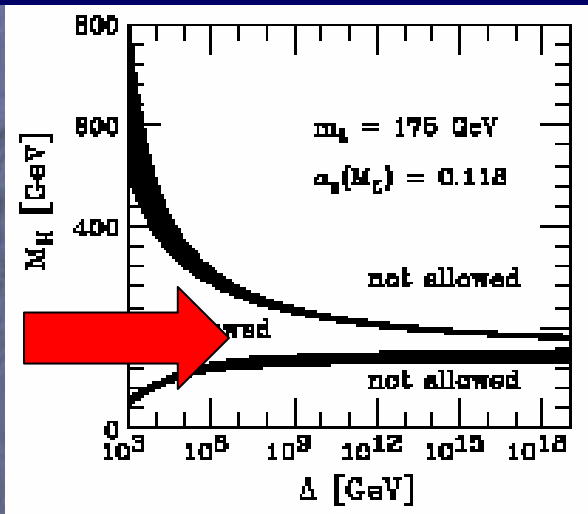
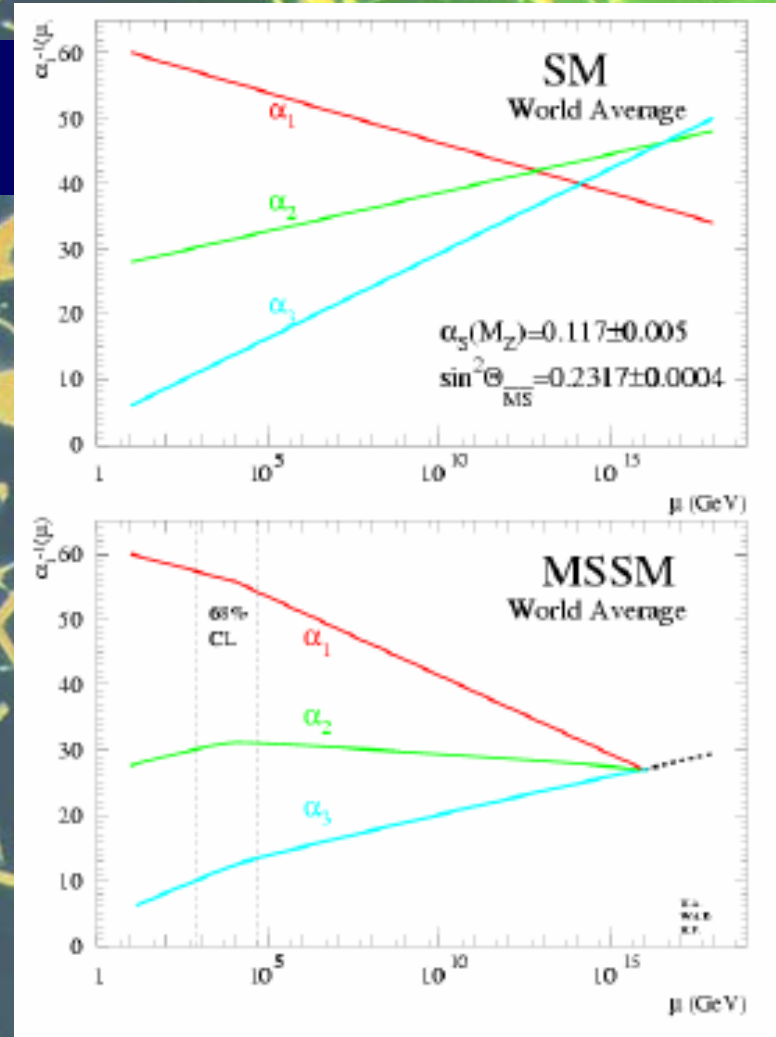

# Dark Matter in the Universe



Astronomers say  
that most of the  
matter in the  
Universe is  
invisible

Dark Matter

'Supersymmetric' particles ?

We shall look for  
them with the  
LHC

# Constraints on Supersymmetry

- Absence of sparticles at LEP, Tevatron

selectron, chargino  $> 100$  GeV

squarks, gluino  $> 250$  GeV

- Indirect constraints

Higgs  $> 114$  GeV,  $b \rightarrow s \gamma$   $g_\mu - 2$

- Density of dark matter

lightest sparticle  $\chi$ :

WMAP:  $0.094 < \Omega_\chi h^2 < 0.124$

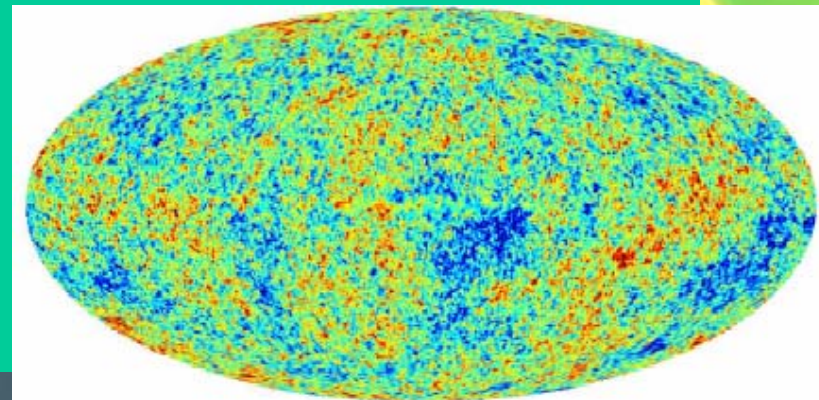
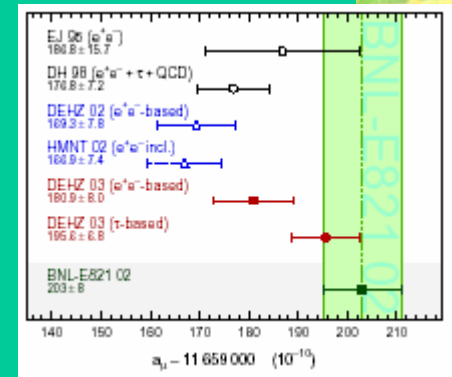

# Supersymmetry Searches at LHC

'Typical' supersymmetric Event at the LHC

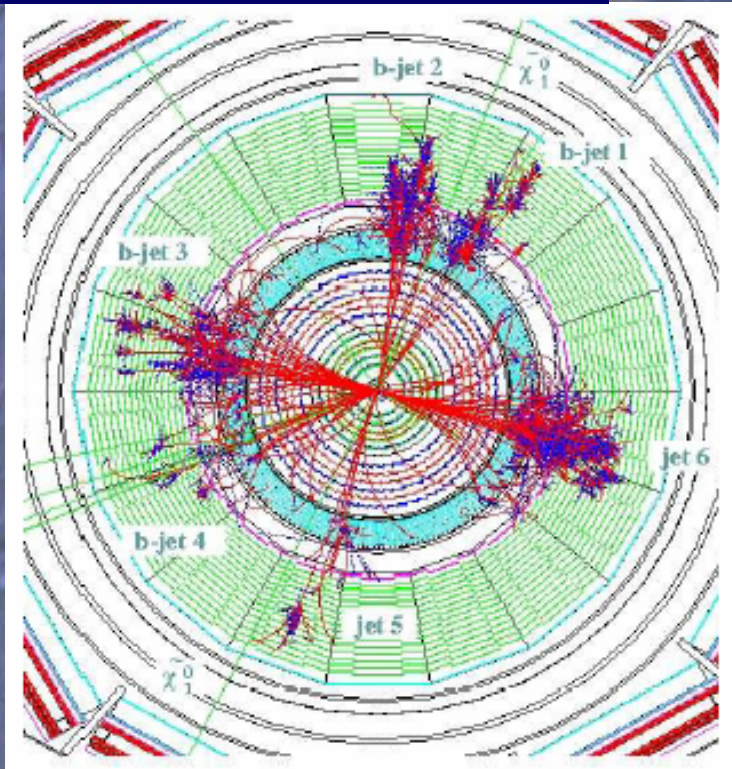

LHC reach in supersymmetric parameter space

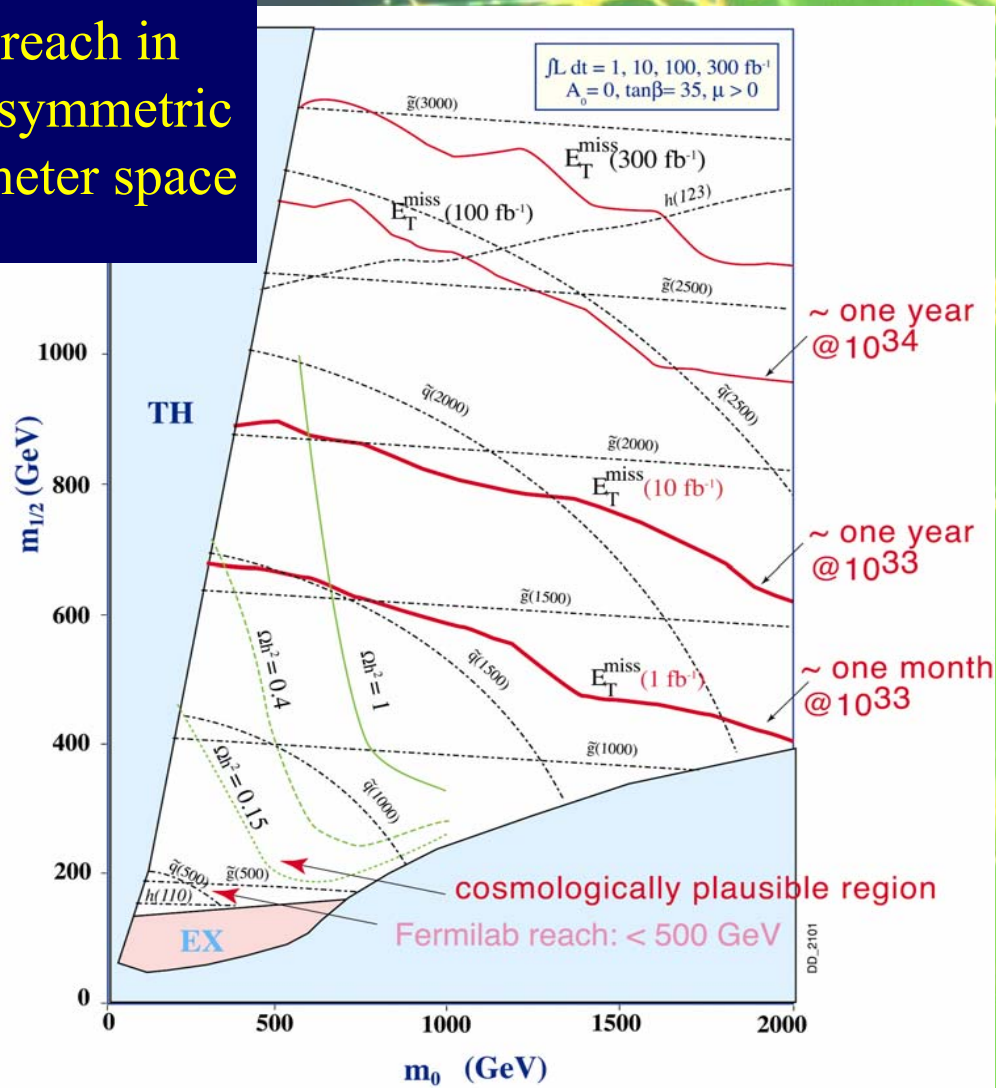

# Supersymmetric Benchmark Studies

Lines in  
susy space  
allowed by  
accelerators,  
WMAP data

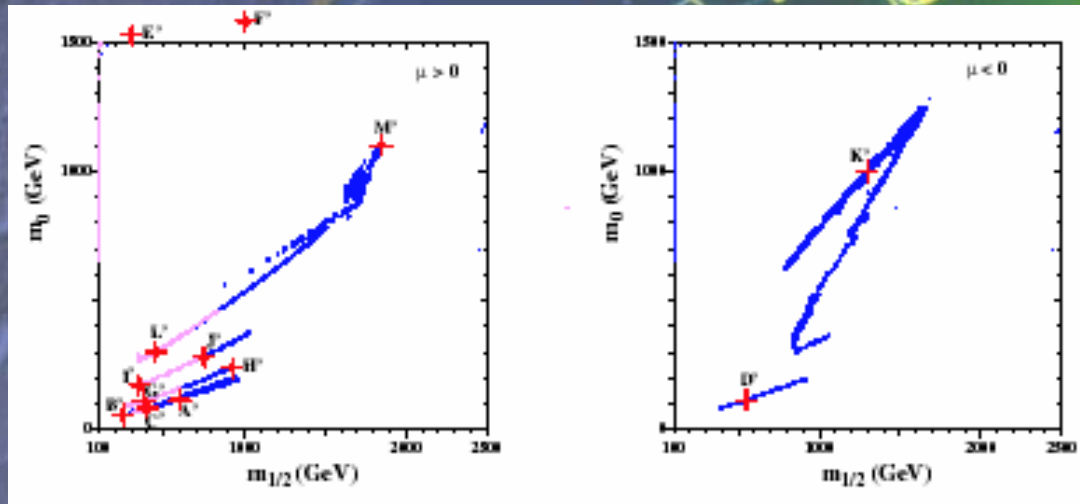

Specific  
benchmark  
Points along  
WMAP lines

Sparticle  
detectability  
Along one  
WMAP line

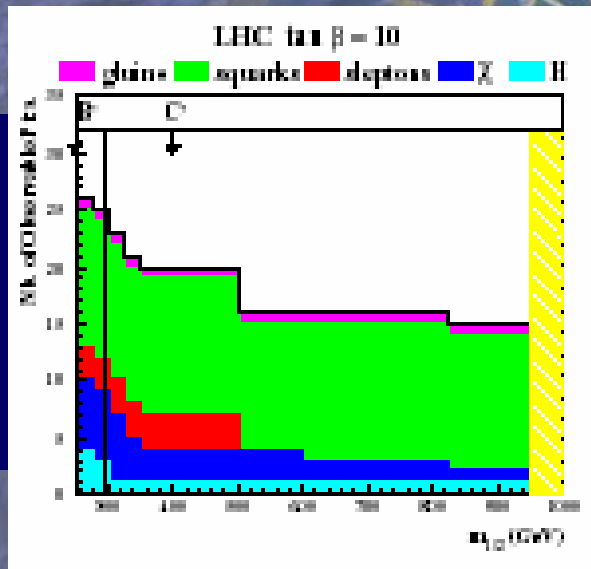

Calculation  
of relic  
density at a  
benchmark  
point

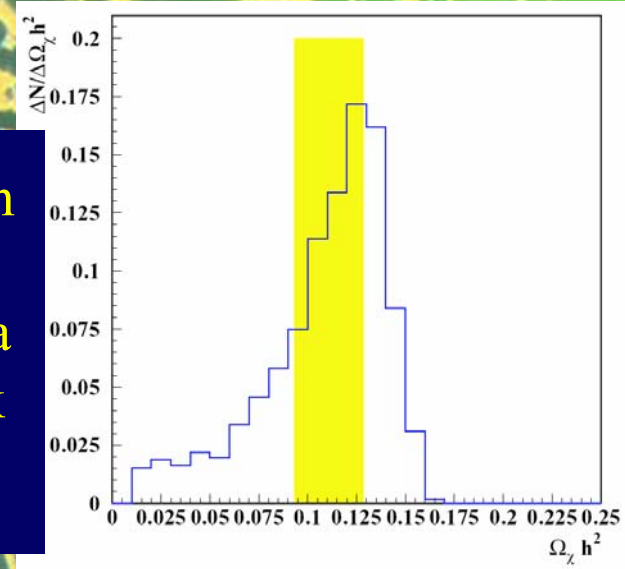

And if there are large extra dimensions & gravity becomes strong at the TeV scale

# Black Hole Production at LHC?

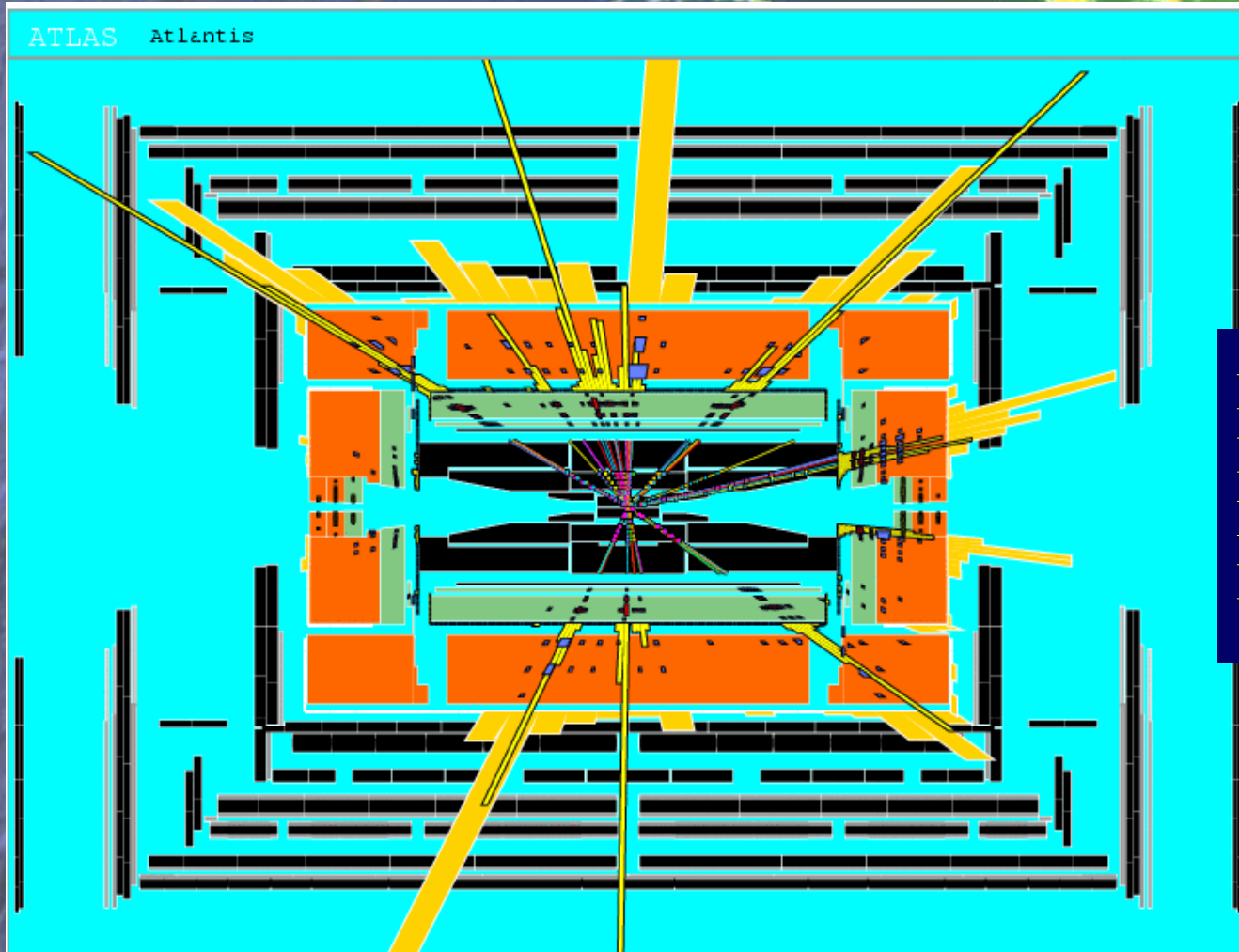

Multiple jets,  
Leptons from  
Hawking  
Radiation

# The Reach of the LHC for New High-Mass Physics

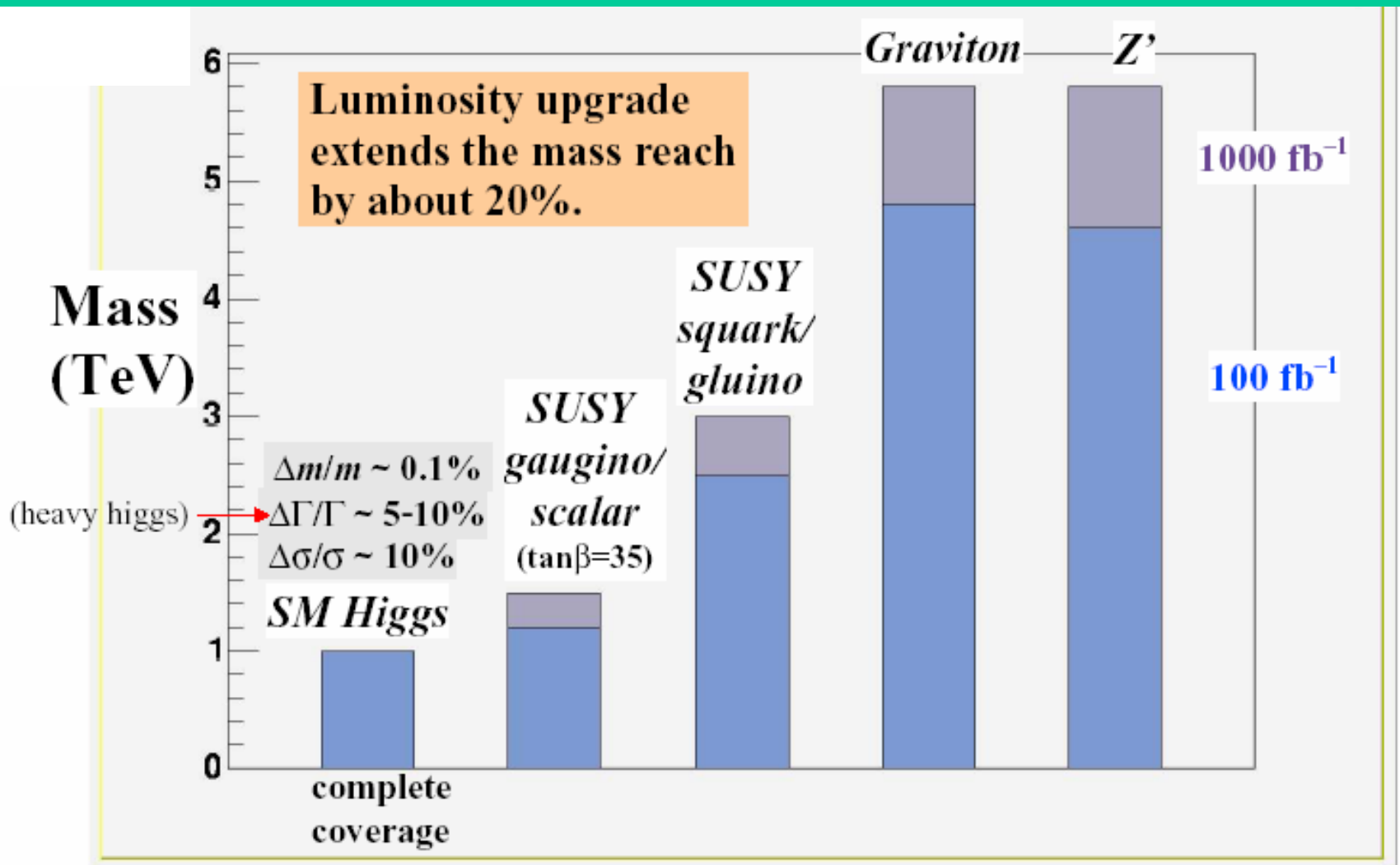

# Hot and Dense Hadronic Matter

Recreate the first  $10^{-6}$  seconds ...

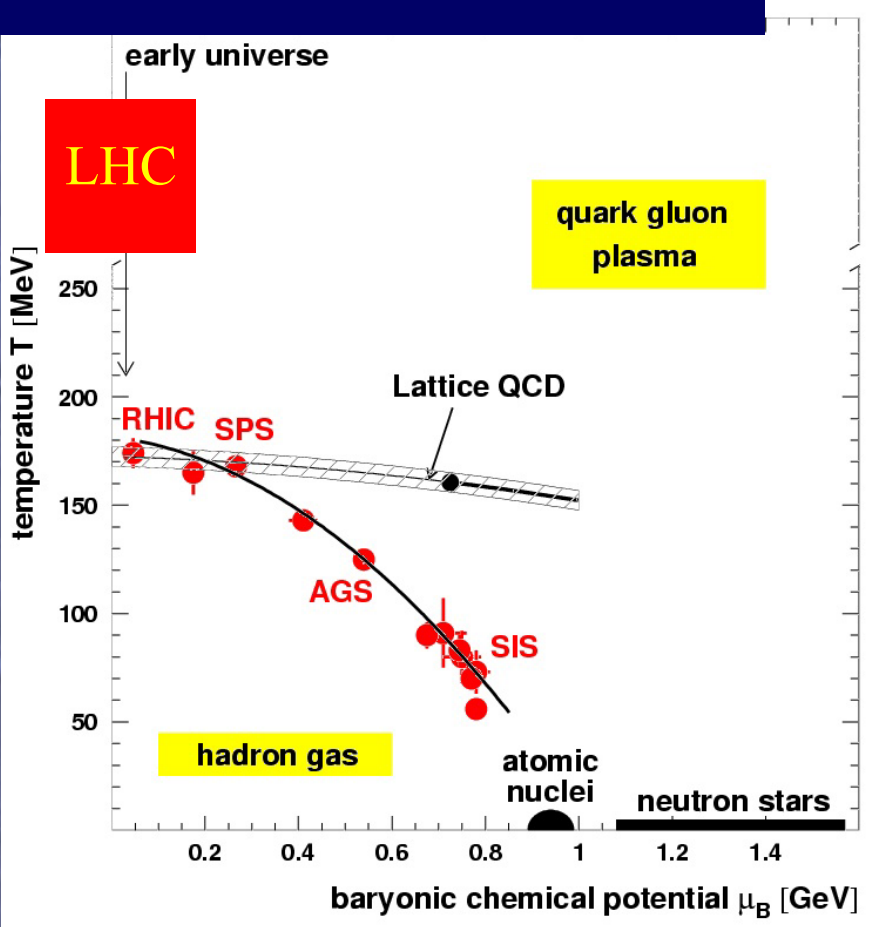

... and probe the quark-hadron phase transition

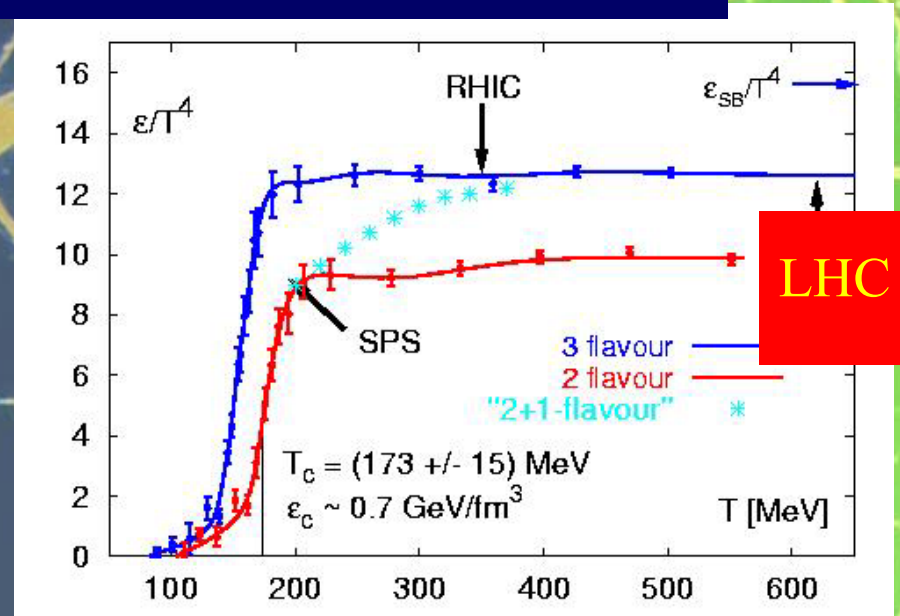



# 'Typical' Heavy-Ion Collision in ALICE

8000 particles  
In the central  
detector ?

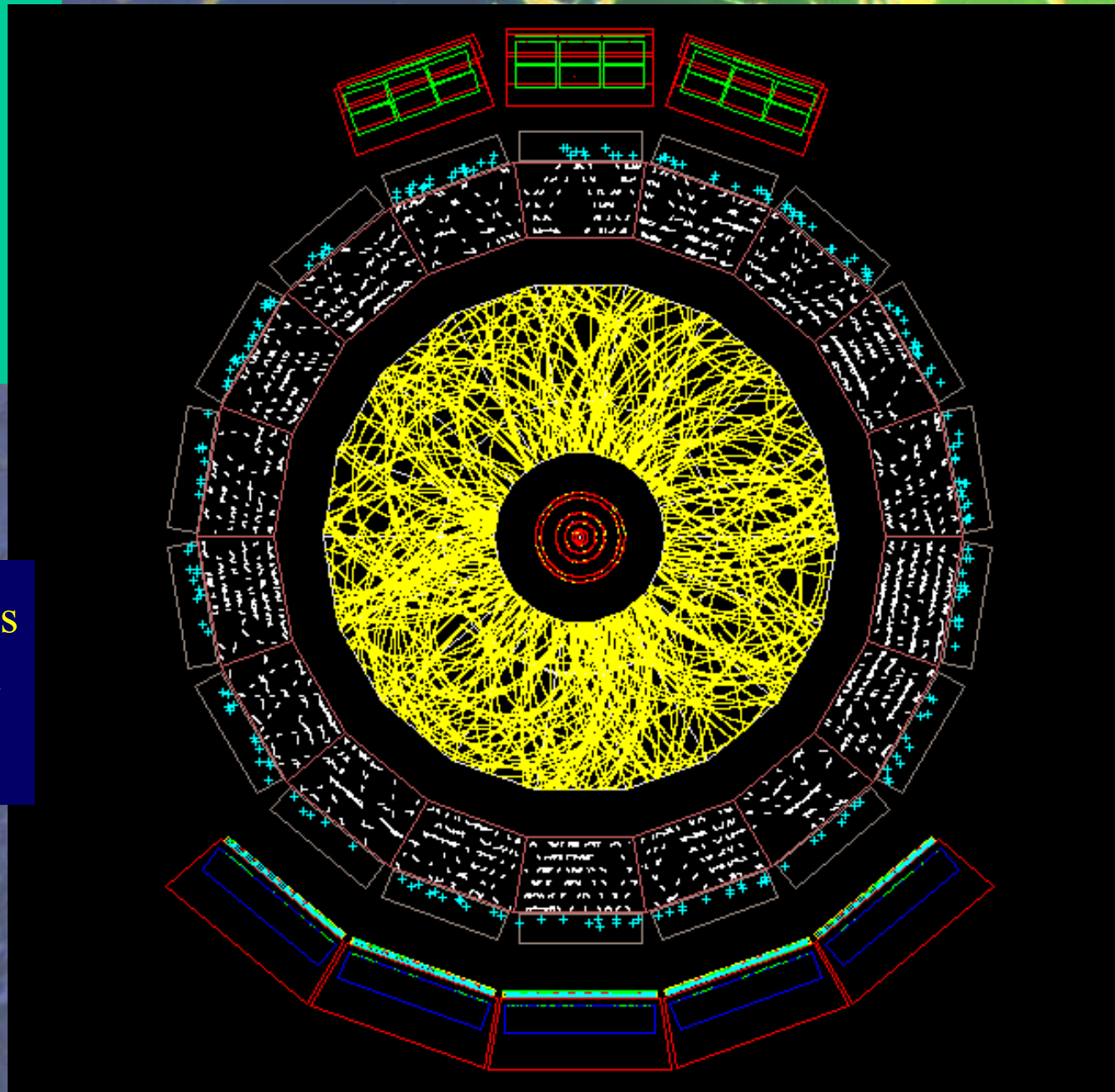

# Computing Grid & Network Projects



CrossGrid



US Projects

European Projects



# LCG1 - Grid Deployment

- Certification and distribution process established
  - Middleware package – components from –
    - European DataGrid (EDG)
    - US (Globus, Condor, PPDG, GriPhyN) → the Virtual Data Toolkit
  - Agreement reached on principles for registration and security
  - RAL (Oxford, UK) to provide the initial grid operations centre
  - FZK (Karlsruhe, Germany) to operate the call centre
- 
- Initial service being deployed now to 10 centres  
US, Europe, Asia
  - Expand to other centres as soon as the service is stable



Academia Sinica Taipei, BNL, CERN, CNAF, FNAL,  
FZK, IN2P3 Lyon, Moscow State Univ., RAL, Univ. Tokyo

# The LHC will Probe New Dimensions of Physics

- A new dimension in energy:  $\sim$  TeV  
Origin of mass ?
- New dimensions of space ?  
More 'familiar' bosonic dimensions ?  
Fermionic 'quantum' dimensions ?
- New dimension of time  
 $\sim 10^{-12}$  sec after Big Bang  
Primordial soup ?  
Dark matter ?  
Origin of matter ?

... and new dimensions in international collaboration

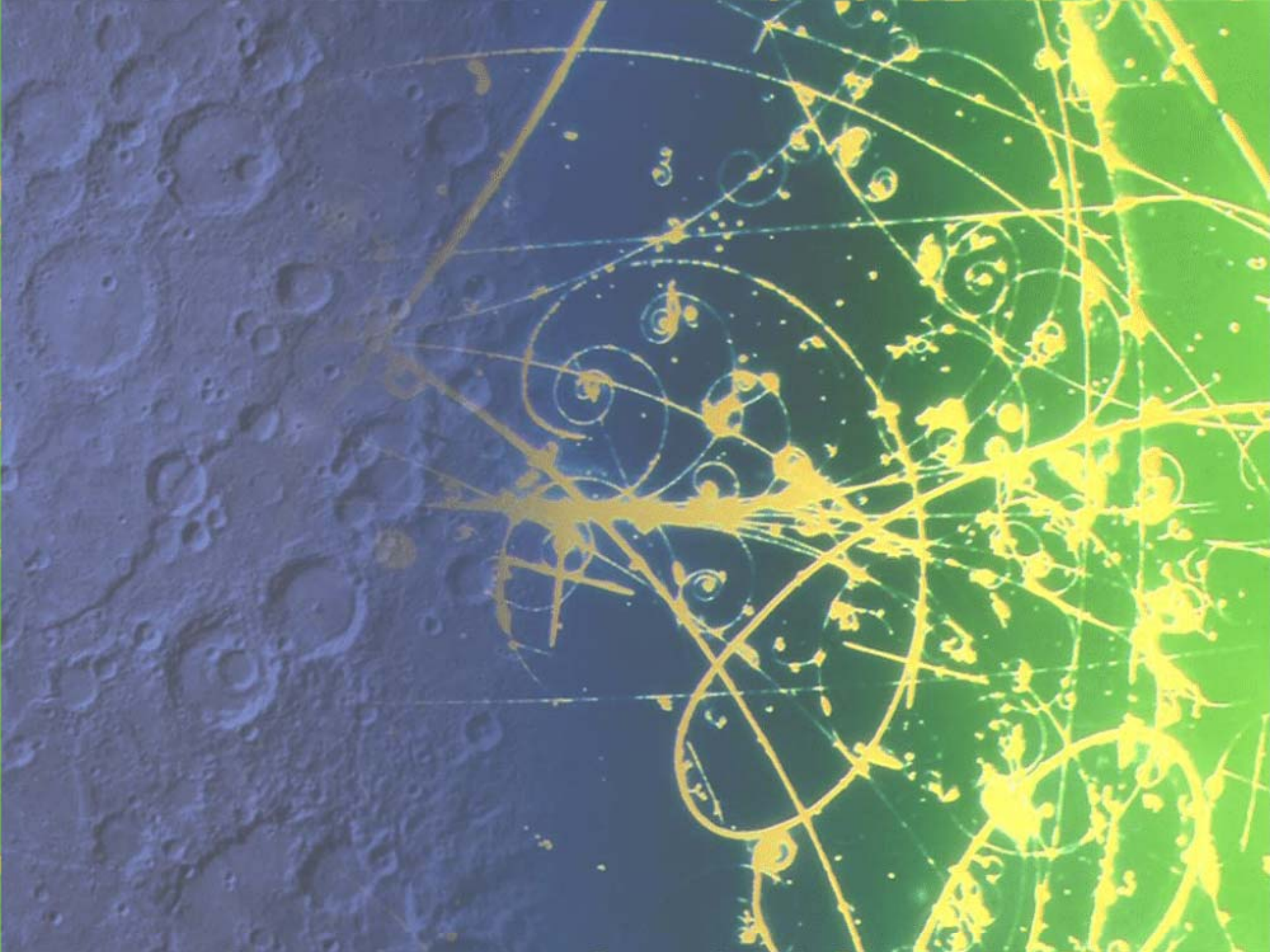

# Not forgetting technicolour ...

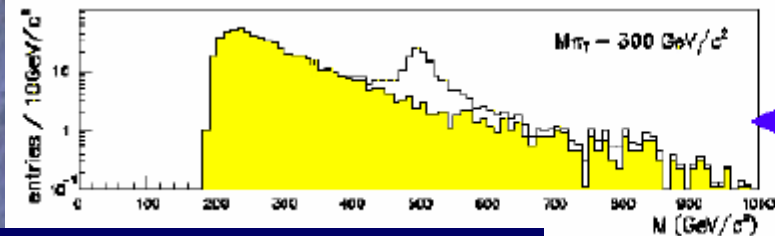

$\rho_T \rightarrow WZ \rightarrow l\nu ll$  for  $30 \text{ fb}^{-1}$   
 (a)  $\sigma \times \text{BR}_{\text{model}} = 0.16 \text{ fb}$   
 $\sigma \times \text{BR}_{5\sigma \text{ discovery}} = 0.025 \text{ fb}$

A techni- $\rho$  resonance ?

# ... or Compositeness

Detectable if  $\Lambda < 50 \text{ TeV}$



**Compositeness**

Contact interaction modifies Drell-Yan

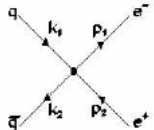

Cross section gets a term  $s/(\alpha\Lambda^2)$ , where  $s = m_{e^+e^-}^2$   
 Dominates when  $s \gg \alpha\Lambda^2$

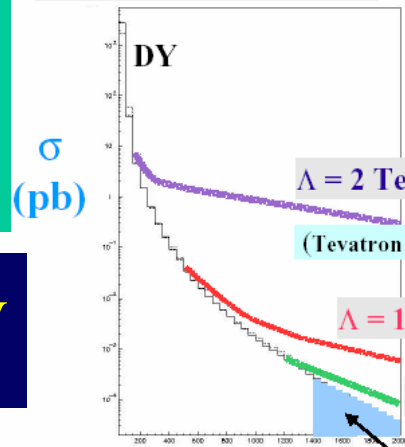

$\sigma$  (pb)

$\Lambda = 2 \text{ TeV}$   
(Tevatron limit)

$\Lambda = 10 \text{ TeV}$

$\Lambda = 20 \text{ TeV}$

132 eV,  $100 \text{ fb}^{-1}$

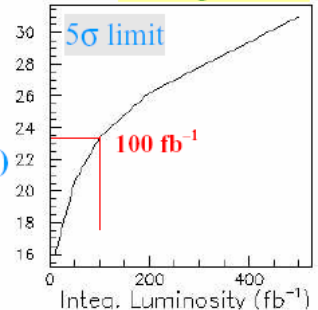

5 $\sigma$  limit

100  $\text{fb}^{-1}$

Integ. Luminosity ( $\text{fb}^{-1}$ )

**A. Gupta et al.**

$1000 \text{ fb}^{-1} \Rightarrow$   
 reach to  $\Lambda = 50 \text{ TeV}$

Complimentary search:  
 jet angular distribution

J. Rohlf, LHC IV p. 30

# Hard Probes of Quark-Gluon Plasma

Look for quarkonium suppression ...

... compare with open charm production

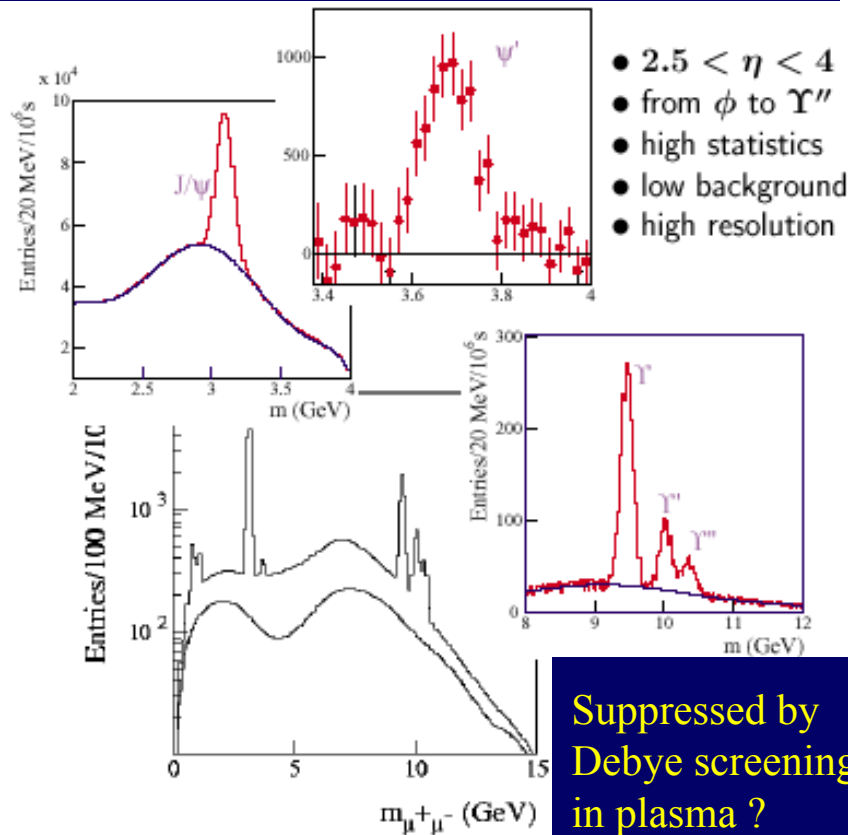

Suppressed by Debye screening in plasma?

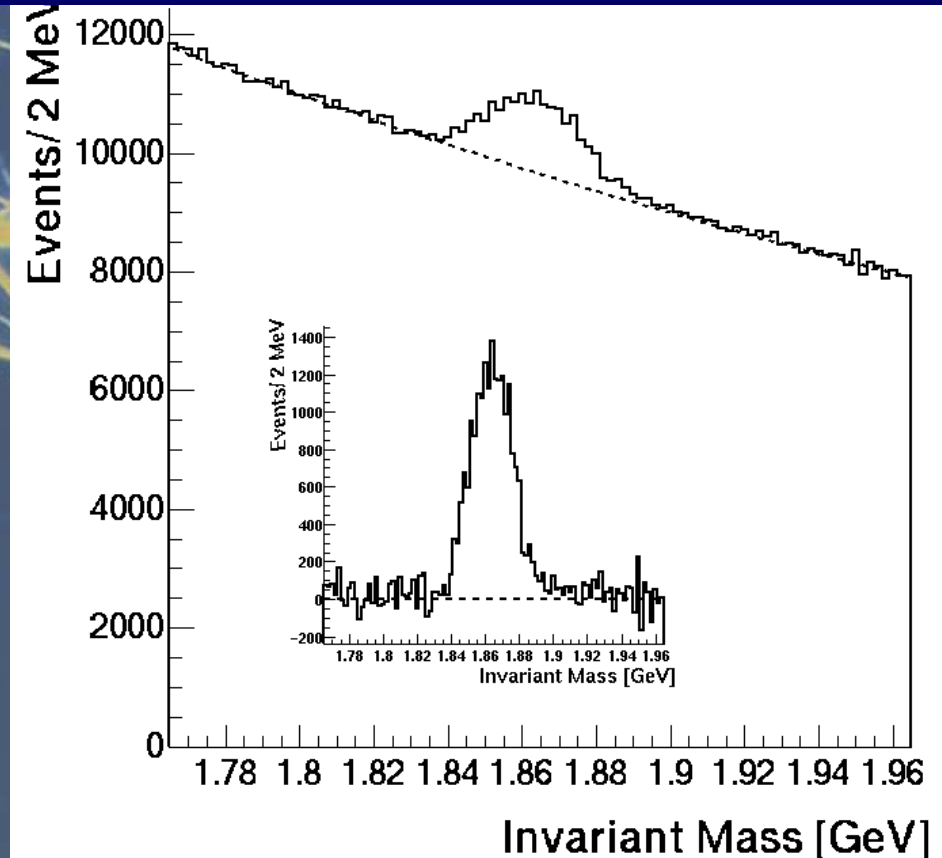

# Z Production in Heavy-Ion Collisions

Look for Z production at large  $p_T$  ...

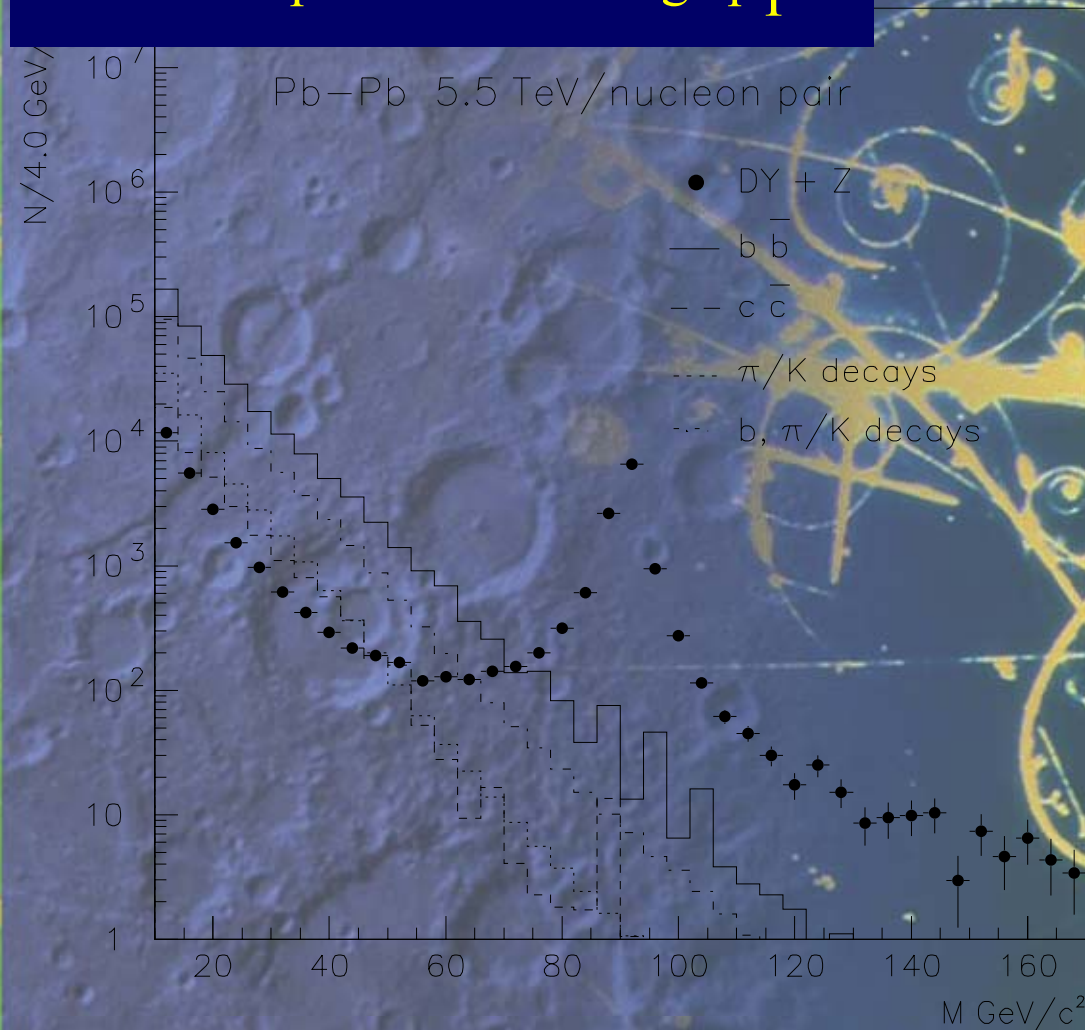

... and absence of jet on opposite side ...

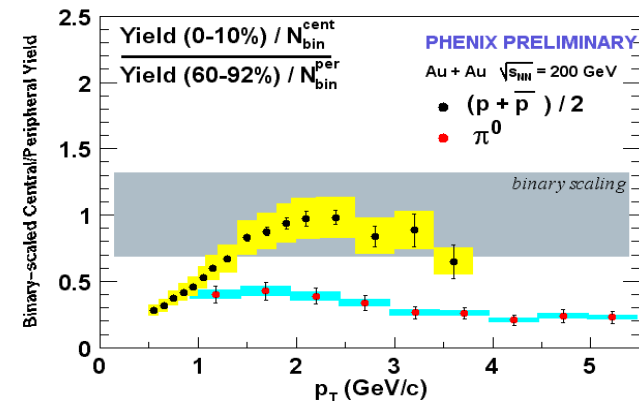

... due to parton absorption in quark-gluon plasma ?

# Probing CP Violation at the LHC

Within the Standard Model ...

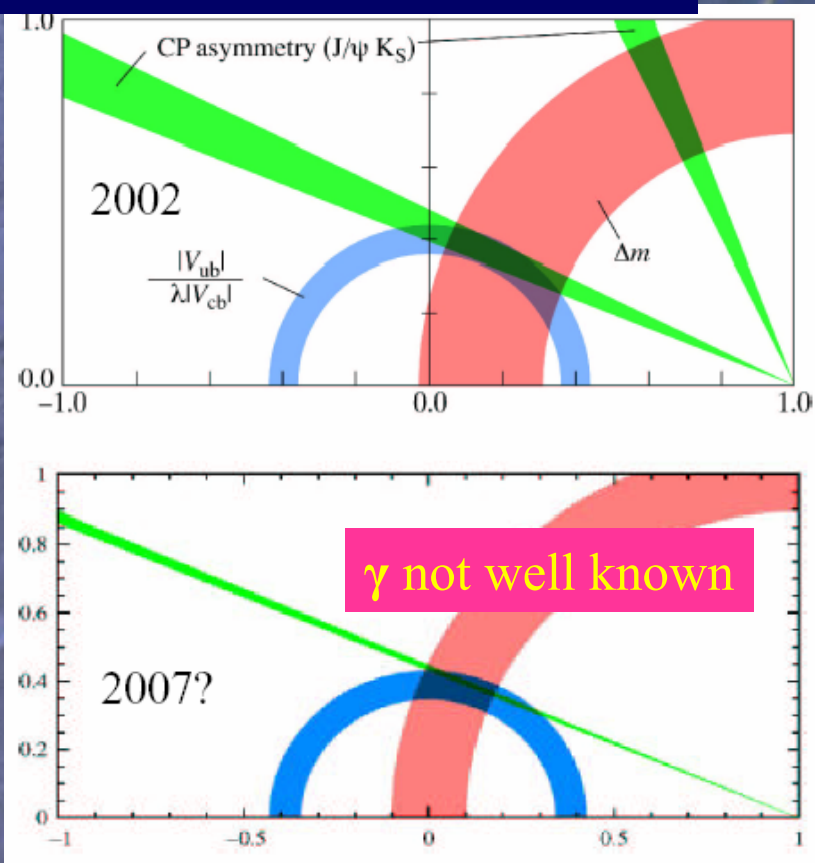

... and beyond it ?

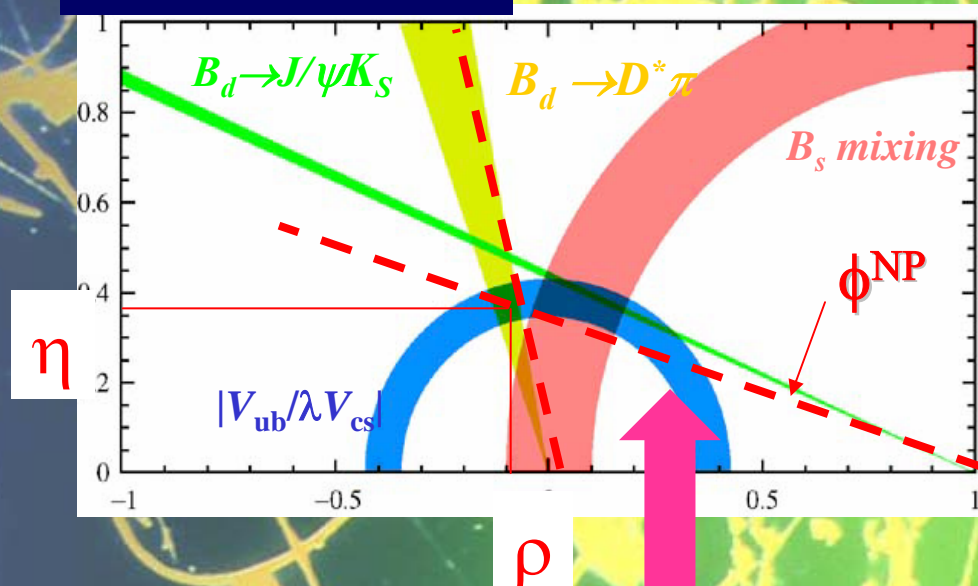

Possible signature of new physics ?

# Sample LHCb Sensitivities

2002 / before / after LHCb

B  $\rightarrow$   $\pi\pi$   
Using  
Cerenkov

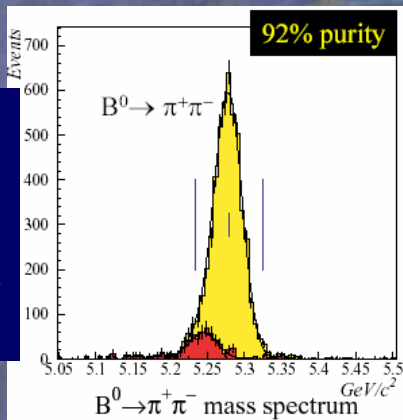

Increase in  
statistics

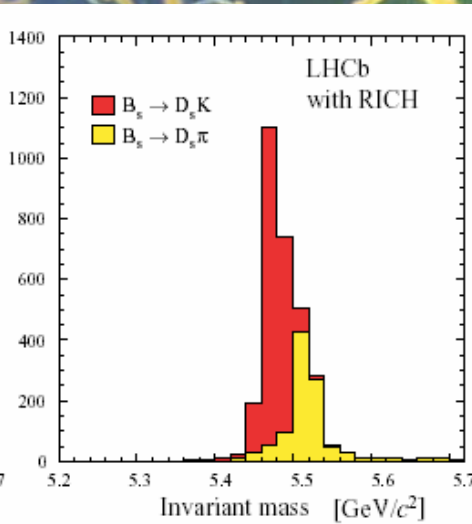
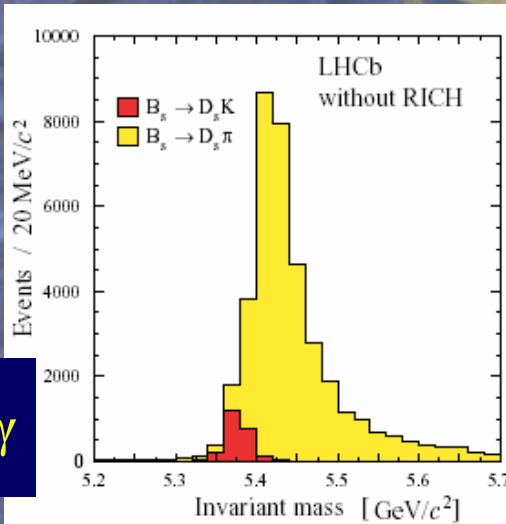
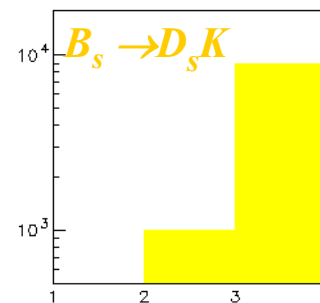
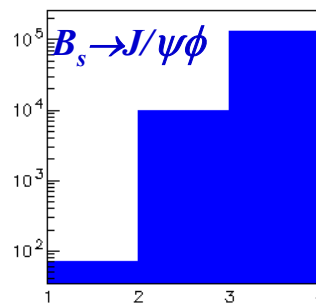
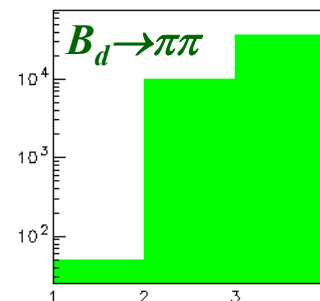
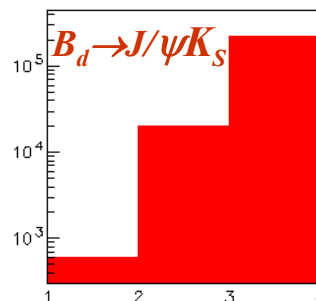

Sensitivity on  $\gamma$  depends on:

- amplitude ratio
- strong phase difference
- $\gamma$
- $\Delta m_s$

For  $\Delta m_s = 20 \text{ ps}^{-1}$ :

$$\sigma(\gamma) = O(10^\circ)$$

Measuring  $\gamma$

# The Electroweak Vacuum

- Generating particle masses requires breaking gauge symmetry:

$$m_{W,Z} \neq 0 \Leftrightarrow \langle 0 | X_I | 0 \rangle \neq 0$$

$$m_W^2 = m_Z^2 \cos^2 \theta_W \Rightarrow I = \frac{1}{2}$$

- $I = \frac{1}{2}$  also needed for fermion masses

- What is X? Elementary or Composite?

# The Electroweak Vacuum

- Generating particle masses requires breaking gauge symmetry:

$$m_{W,Z} \neq 0 \Leftrightarrow \langle 0 | X_I | 0 \rangle \neq 0$$

$$m_W^2 = m_Z^2 \cos^2 \theta_W \Rightarrow I = \frac{1}{2}$$

- $I = \frac{1}{2}$  also needed for fermion masses

- What is X? Elementary or Composite?

A la recherche du Higgs perdu ...

# Higgs Production at the LHC

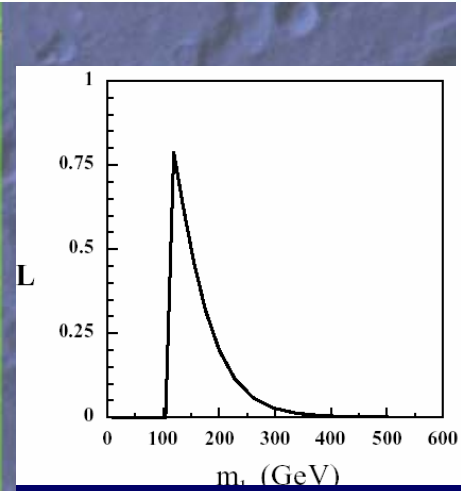
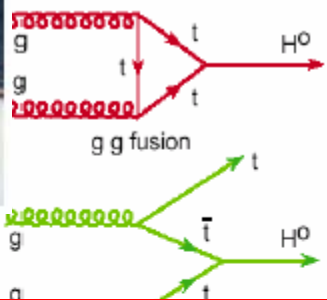
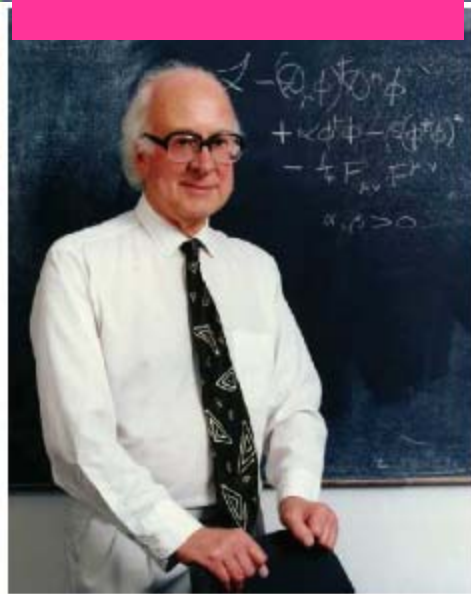

.. not far away?

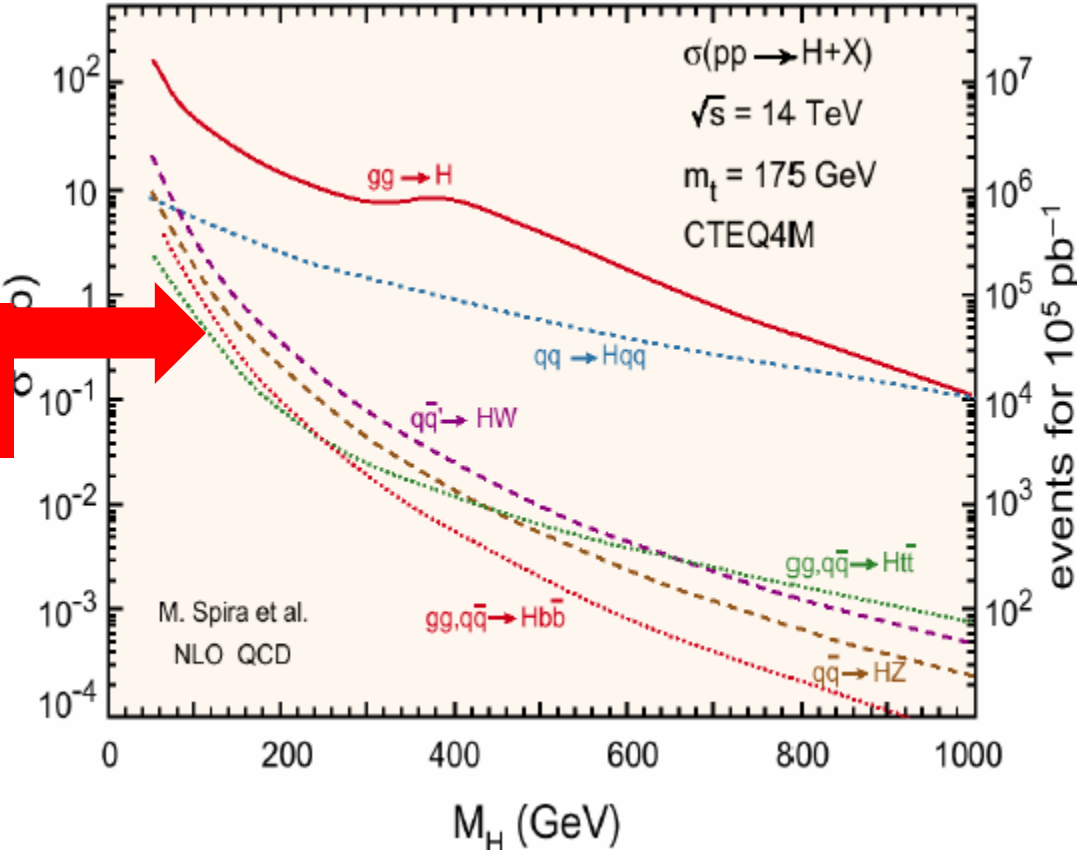
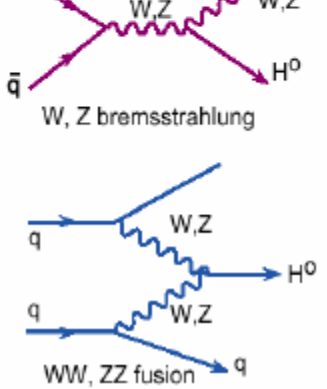

Combining direct, Indirect information

# Summary of LHC Scapabilities ... and Other Accelerators

LHC almost  
'guaranteed'  
to discover  
supersymmetry  
if it is relevant  
to the mass problem

